

HSABC ALGORITHM FOR ECONOMIC OPERATION EMISSION BASED

^{1,2,*}ARIF NUR AFANDI, ²FARREL CANDRA WINATA AFANDI

¹Department of Electrical Engineering and Informatics, Universitas Megeri Malang, Malang, Indonesia

²Smart Power and Advanced Energy Systems (SPAES) Research Center, Batu, Indonesia

e-mail: an.afandi@um.ac.id

*Corresponding author

ABSTRACT

The total cost of maintaining the energy infrastructure is one of the most critical problems. Technically, this issue considers the fuels and emissions of generating units working within specific parameters in an Economic Operation Emission Based (EOEB). This study evaluates the performance of the Harvest Season Artificial Bee Colony (HSABC) Algorithm in search of the best EOEB solution. To compute the EOEB issue on the IEEE-62 bus system, simulation programming techniques are applied based on HSABC Algorithm. The simulation findings indicate that the investigated approaches have a range of characteristics, speed, starting, and statistical value values. Considering the problem based on 19 generating units, the HSABC parameters which are incorporated into each foraging cycle to seek solutions, are used to execute the designed optimization programs. The EOEB problem is resolved in these investigations using the HSABC Algorithm based on statements and computing hierarchies whereas load needs of the system are supplied in terms of power needed at the load center, fuel cost and emission coefficients of generating units are utilized to present the power unit consumption. Moreover, the overall load covered in 2,912 MW where the IEEE-62 bus system produced a total of 2,952.77 MW of power, including 40.77 MW of total loss. Moreover, the optimal operation is discharged emission in 5.789,29 kg besides all the function also spent in 28.720,49

Keywords: Bee, Cost, Economic, Emission, Power System

1. INTRODUCTION

Under operational restrictions, a power system transmits electric energy from generators to load areas, considered the least expensive option. Pollutant emissions are also considered in the problem as an Emission Dispatch. The technical running cost is frequently approached by applying an Economic Dispatch of generating units owing to a total load demand at a given moment [1]–[3]. The problem is assembled into an Economic Operation Emission Based (EOEB) as the single objective function to determine the best committed generating unit outputs. It is possible to use various strategies to solve the EOEB problem. Different from conventional and evolutionary techniques, numerous techniques have been developed for the best solutions. However, they struggle with complex systems and multiple spaces. Traditional approaches are practical and useful for finding solutions.

On the other hand, evolutionary techniques have emerged as alternatives to enhance the capabilities of traditional techniques [4]–[6]. These procedures are made up of clever ways to determine ideal outcomes. Evolutionary techniques are now commonly employed to highlight distinct instances of optimization.

This research assesses the effectiveness of an evolutionary strategy while considering the EOEB and uses the IEEE-62 bus as a representative model of the power system. To solve EOEB's problems, the Harvest Season Artificial Bee Colony (HSABC) Algorithm is provided. Numerous flowers are expressed in the HSABC algorithm using Multiple Food Sources (MFSs), which include the First Food Source (FFS) and Other Food Sources (OFSs). Each food source in the harvest season region is randomly located at a specific location by a harvest operator acting as the MFS [7]. While employing a greedy process to find the best solution, the FFS and OFSs work together to present potential answers for all foraging cycles.

2. RESEARCH METHODOLOGY

2.1 The HSABC Algorithm's

The HSABC algorithm's sequencing computation is performed in various steps, as the pseudo-codes show. HSABC is given as the following claims when processes are taken into account processes. Generating population: create initial population sets, evaluate initial population sets, and define the final population. Food source exploration: produce the FFS, produce the OFSS, evaluate the MFSs, apply the greedy process, and calculate the probability values. Food selection: produce a new food, produce neighbor foods, evaluate foods, and apply the greedy process. Abandoned replacement: determine an abandoned food, replace with a new randomly one, and memorize the optimal foods.

The sources clearly discuss the HSABC algorithm's rules and operations. The following key expressions are used to present the HSABC method mathematically:

$$v_{yj} = x_{yj} + \emptyset_{yj}(x_{yj} - x_{kj}), \quad (1)$$

$$H_{yho} = \begin{cases} x_{kj} + \emptyset_{yj}(x_{kj} - x_{fj})(ho - 1), & \text{for } R_j < MR \\ x_{kj}, & \text{otherwise} \end{cases}, \quad (2)$$

$$x_{yj} = x_{minj} + \text{rand}(0,1) * (x_{maxj} - x_{minj}), \quad (3)$$

$$\text{fit}_y = \begin{cases} \frac{1}{1+F_y}, & \text{for } F_y \geq 0 \\ 1 + \text{abs}(F_y), & \text{if } F_y \leq 0 \end{cases}, \quad (4)$$

$$p_y = \frac{\text{fit}_y}{\sum_{y=1}^{SN} \text{fit}_y}, \quad (5)$$

where x_{yj} is the current food source; y is the y^{th} solution of the food source; $k \in \{1,2,3,\dots,SN\}$, $j \in \{1,2,3,\dots,D\}$, where SN is the number of solutions, and D is the number of variables of the problem; \emptyset_{yj} is a random number in $[-1,1]$; v_{yj} is the food position; x_{kj} is a random neighbor of x_{yj} ; x_{fj} is a random harvest neighbor of x_{kj} ; H_{yho} is the harvest season food position; $ho \in \{2,3,\dots,FT\}$, $f \in \{1,2,3,\dots,SN\}$, FT is the total number of food sources; R_j is a random real number in $[0,1]$; MR is the modified rate of food probability; x_{minj} is the minimum limit of x_{yj} ; x_{maxj} is the maximum limit of x_{yj} ; F_y is an objective function of the y^{th} solution of the food; fit_y is the fitness value of the y^{th} solution; and p_y is the probability of the y^{th} quality of food.

In particular, a challenge of EOEB is addressed to reduce the total cost of fuel and the total cost of emissions in a single objective function while considering various power system constraints [1], [8]–[10]. In essence, this issue has grown into a significant task in the operation of the power system, and both issues can be combined by adding a penalty factor and a compromised factor [7], [11], [12]. The EOEB has a single objective function and can function under many constraints. The following mathematical functions typically express the dispatching problem:

$$F_i(P_i) = c_i + b_i P_i + a_i P_i^2, \quad (6)$$

$$\text{Economic minimize } F_{tc} = \sum_{i=1}^{ng} (c_i + b_i \cdot P_i + a_i \cdot P_i^2), \quad (7)$$

$$E_i(P_i) = \gamma_i + \beta_i \cdot P_i + \alpha_i \cdot P_i^2, \quad (3)$$

$$\text{Emission minimize } E_t = \sum_{i=1}^{ng} (\gamma_i + \beta_i \cdot P_i + \alpha_i \cdot P_i^2), \quad (8)$$

$$h_i = \frac{F_i(P_i^{\max})/P_i^{\max}}{E_i(P_i^{\max})/P_i^{\max}}, \quad (5)$$

$$\text{EOEB minimize } \Phi = w \cdot F_{tc} + (1 - w) \cdot h \cdot E_t, \quad (9)$$

$$\sum_{i=1}^{ng} P_i = P_D + P_L, \quad (10)$$

$$P_{Gp} = P_{Dp} + V_p \sum_{q=1}^{nBus} V_q (G_{pq} \cdot \cos\theta_{pq} + B_{pq} \cdot \sin\theta_{pq}), \quad (11)$$

$$Q_{Gp} = Q_{Dp} + V_p \sum_{q=1}^{nBus} V_q (G_{pq} \cdot \sin\theta_{pq} - B_{pq} \cdot \cos\theta_{pq}), \quad (12)$$

$$P_L = \sum_{p=1}^{ng} \sum_{q=1}^{ng} P_p \cdot B_{pq} \cdot P_q + \sum_{p=1}^{ng} B_{0p} \cdot P_p + B_{00}, \quad (13)$$

$$P_i^{\min} \leq P_i \leq P_i^{\max}, \quad (14)$$

$$Q_i^{\min} \leq Q_i \leq Q_i^{\max}, \quad (15)$$

$$V_p^{\min} \leq V_p \leq V_p^{\max}, \quad (16)$$

$$S_{pq} \leq S_{pq}^{\max}, \tag{17}$$

where F_i is a fuel cost of i^{th} generating unit (\$/hr), P_i is a output power of i^{th} generating unit, a_i, b_i, c_i are fuel cost coefficients of i^{th} generating unit, F_{ic} is a total fuel cost, n_g is number of generating unit, E_i is an emission of i^{th} generating unit (kg/hr), $\alpha_i, \beta_i, \gamma_i$ are emission coefficients of i^{th} generating unit, E_t is a total emission (kg/hr), h_i is each penalty factor of i^{th} generating unit, Φ is the EOEB (\$/hr), w is a compromised factor, h is a penalty factor selected from ascending order of h_i for the P_D , P_D is a total power load demand, P_L is a total transmission loss, P_{Gp} and Q_{Gp} are power injections of load flow at bus p , P_{Dp} and Q_{Dp} are load demands of load flow at bus p , P_p and P_q are power injections at bus p and q , P_i^{\min} is a minimum output power of i^{th} generating unit, P_i^{\max} is a maximum output power of i^{th} generating unit, Q_i^{\max} and Q_i^{\min} are maximum and minimum reactive powers of i^{th} generating unit, V_p^{\max} and V_p^{\min} are maximum and minimum voltages at bus p , V_p and V_q are voltages at bus p and q , S_{pq} is a total power transfer between bus p and q , S_{pq}^{\max} is a limit of power transfer between bus p and q .

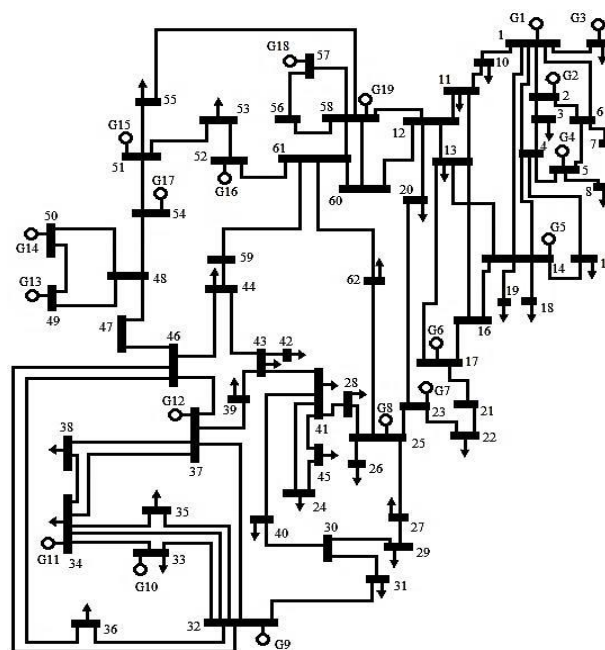

Figure 1. One-line diagram of IEEE-62 bus system

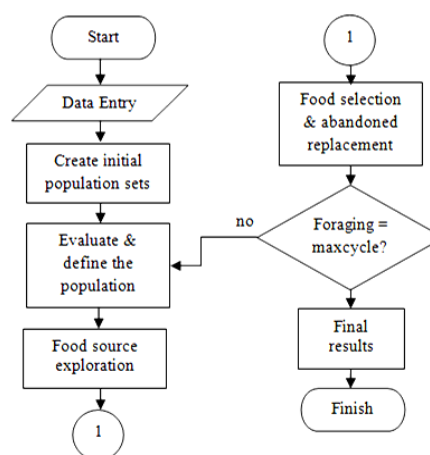

Figure 2. Flow chart for solving the EOEB problem

Table 1. Load Demands of the Sample System

Bus	MW	MVar	Bus	MW	MVar	Bus	MW	MVar	Bus	MW	MVar
1	0.0	0.0	32	0.0	0.0	17	0.0	0.0	48	0.0	0.0
2	0.0	0.0	33	46.0	25.0	18	121	46.0	49	0.0	0.0
3	40.0	10.0	34	100	70.0	19	130	70.0	50	0.0	0.0
4	0.0	0.0	35	107	33.0	20	80.0	70.0	51	0.0	0.0
5	0.0	0.0	36	20.0	5.0	21	0.0	0.0	52	0.0	0.0
6	0.0	0.0	37	0.0	0.0	22	64.0	50.0	53	248	78.0
7	0.0	0.0	38	166	22.0	23	0.0	0.0	54	0.0	0.0
8	109	78.0	39	30.0	5.0	24	28.0	34.0	55	94.0	29.0
9	66.0	23.0	40	25.0	5.0	25	0.0	0.0	56	0.0	0.0
10	40.0	10.0	41	92.0	91.0	26	116	52.0	57	0.0	0.0
11	161	93.0	42	30.0	25.0	27	85.0	35.0	58	0.0	0.0
12	155	79.0	43	25.0	5.0	28	63.0	8.0	59	0.0	0.0
13	132	46.0	44	109	17.0	29	0.0	0.0	60	0.0	0.0
14	0.0	0.0	45	20.0	4.0	30	77.0	41.0	61	0.0	0.0
15	155	63.0	46	0.0	0.0	31	51.0	25.0	62	93.0	23.0
16	0.0	0.0	47	0.0	0.0						

Table 2. Power Limits of Generators

No	Bus	Gen	Pmin (MW)	Pmax (MW)	Qmax (MVar)	Qmin (MVar)	No	Bus	Gen	Pmin (MW)	Pmax (MW)	Qmax (MVar)	Qmin (MVar)
1	1	G1	50	300	0	450	11	34	G11	50	150	-50	200
2	2	G2	50	450	0	500	12	37	G12	0	50	0	75
3	5	G3	50	450	-50	500	13	49	G13	50	300	-50	300
4	9	G4	0	100	0	150	14	50	G14	0	150	-50	200
5	14	G5	50	300	-50	300	15	51	G15	0	500	-50	550
6	17	G6	50	450	-50	500	16	52	G16	50	150	-50	200
7	23	G7	50	200	-50	250	17	54	G17	0	100	0	150
8	25	G8	50	500	-100	600	18	57	G18	50	300	-50	400
9	32	G9	0	600	-100	550	19	58	G19	100	600	-100	600
10	33	G10	0	100	0	150							

2.2 Running Test System

The designed programs are used to the IEEE-62 bus system as a sample model of a power system to demonstrate the performances of various steps of HSABC. This system has 89 lines, 62 buses, and 19 generators as detailed in Figure 1. The adopted model is depicted in one line diagram in this work. Whereas load needs of the system are supplied in terms of power needed at the load center, fuel cost and emission coefficients of generating units are utilized to present the power unit consumption [13].

Locations of individual load demands and generating units are shown in this section related to their coefficients, as shown in Table 1 and Table 2. According to references, additional technical information about the sample system is linked to the IEEE-62 bus system's Appendix Data. The EOEB has been demonstrated using a number of operational constraints, including 5% fluctuated voltage limits, 95% maximum transmission transfer capabilities, an equality of powers, power limits, 15% maximum power loss, and 0,5 compromised factor, to evaluate the effects of performances. Following a number of conditions, including flowers=2, colony size=50, food number=25, and foraging cycles=200, the HSABC algorithm has also been implemented to the sample system. The three categories of designed simulation programs are Data Input Program, EOEB Program, and Algorithm Program. The Data Input Program consists of a number of parameters, including generating units, transmission lines, loads, restrictions, and parameters. The EOEB Program was created to compute an objective function under practical restrictions. The number of EOEB variables is related to examining the limits of the food supply. An algorithm program built on each ongoing hierarchy is used to look for the ideal solution to the EOEB problem as presented in Figure 2. In order to research food sources and choose the best one, this application combines three distinct kinds of components. Programming executions choose the best meal by using a greedy algorithm on each cycle.

3. RESULT AND DICUSSION

In general, provided energy of the power system is supplied by combined generating units as the whole

operation [2], [14], [15]. These studies use a variety of constraints to address simulations to arrive at a minimum solution to the EOEB problem. The HSABC parameters, which are incorporated into each foraging cycle to seek solutions, are used to execute the designed programs for each algorithm. The EOEB problem is resolved in these investigations using the HSABC Algorithm based on statements and computing hierarchies [7]. In the random candidates of the foods for all generating units as solution groups [16], a set initial population is depicted concerning the power limits of the generating units which these constraints are used to locate the appropriate solutions within the practical bounds of the authorized power outputs for each producing unit as depicted in Figure 1.

Refer to some previous works that intelligent optimization has fast speed to determine solutions that it worked on greedy based processes [4], [5], [17]. So, Figure 4 demonstrates each algorithm's greedy technique for arriving at a solution. This graph shows how to choose food based on fitness level to attain the greatest outcomes for each cycle. The EOEB IS used to show how well this way to perform solutions during computations while considering all simulation-related factors. Only the best response is sought in all foraging cycles that employ the EOEB least cost outcome based on the initial population as given in Figure 3. Every step makes to reach a final answer yields a result as detailed in Figure 6, and each cycle for each type of technique. This figure shows that each path walks randomly in the range of all distances for all steps during determining the optimal solution. The lowest EOEB in these experiments is determined using 0.5 of a compromised factor. These findings demonstrate the HSABC's performance for resolving the EOEB problem while operating under operational constraints which is timed in Figure 5.

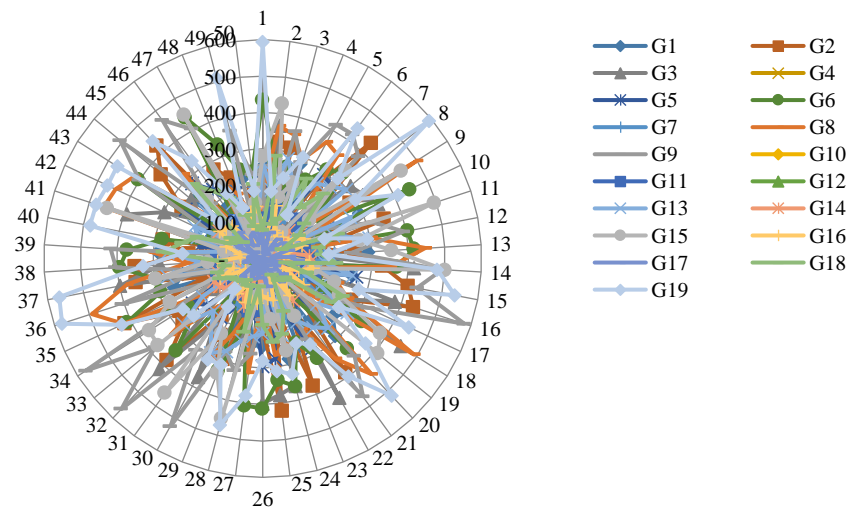

Fig. 3. Initial population the running test system

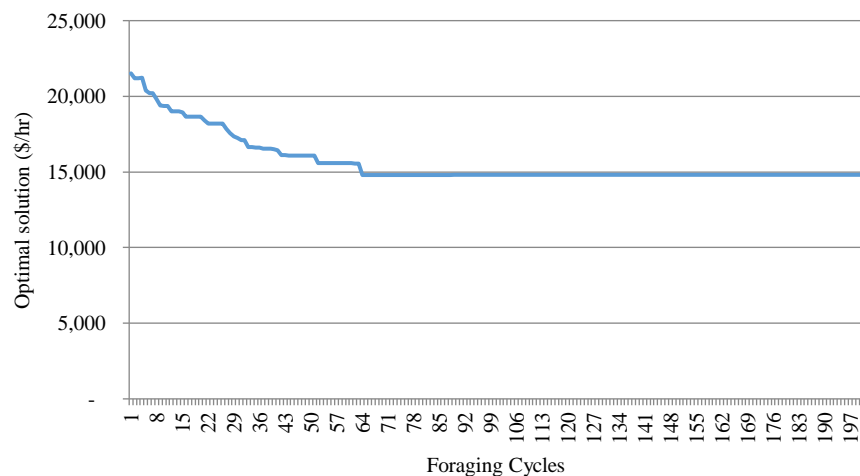

Figure 4. Computational speed of HSABC Algorithm

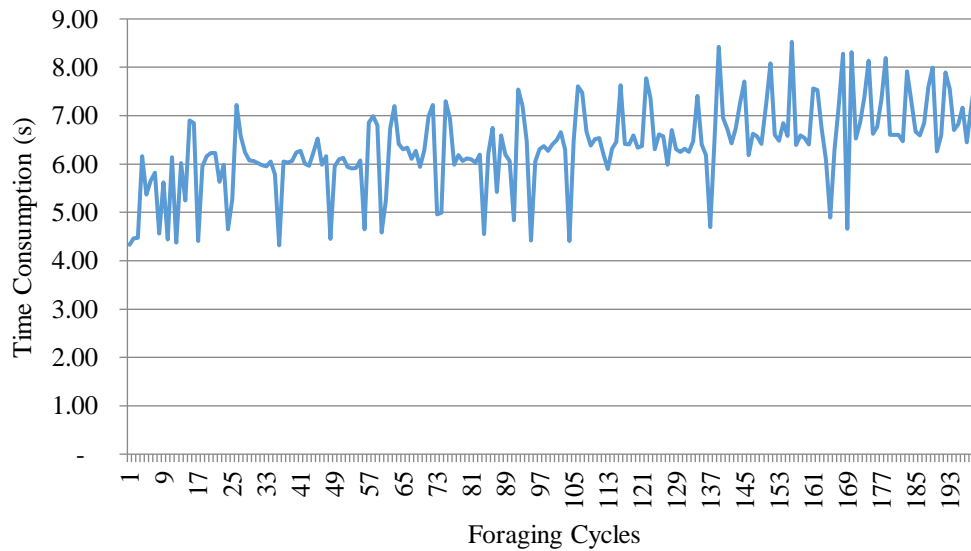

Figure 5. Time consumption of HSABC Algorithm

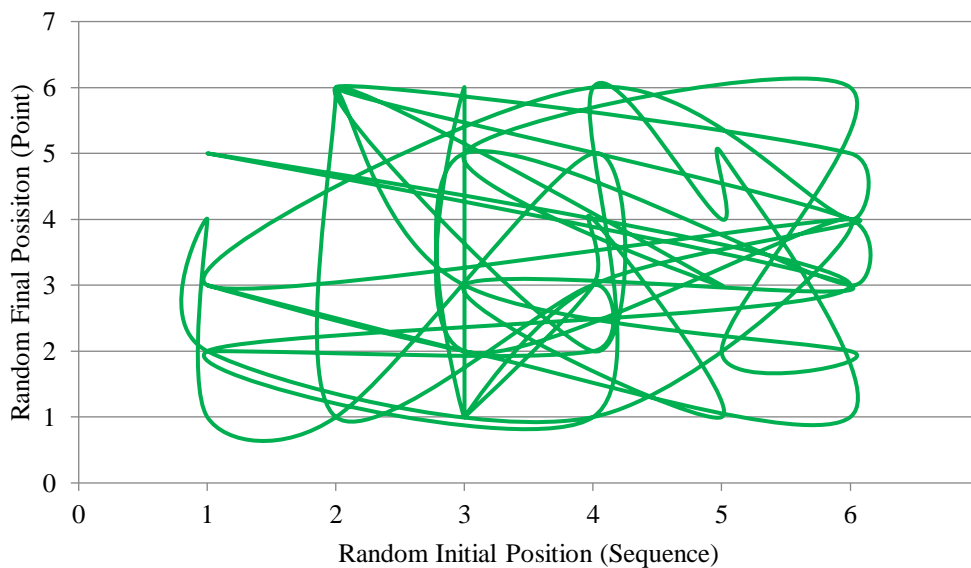

Figure 6. Random walk computation of HSABC Algorithm

Table 3. Optimal Power Production and Charge

Units	Power (MW)	Emis. (kg/hr)	Fuel cost (\$/hr)	Emis. Cost (\$/hr)	Total cost
G1	212.25	451.06	1,853.70	1,159.31	3,013.00
G2	148.87	386.23	747.39	992.68	1,740.07
G3	149.67	392.05	766.86	1,007.66	1,774.52
G4	100.64	28.99	120.87	74.51	195.38
G5	236.16	600.76	1,440.99	1,544.07	2,985.06
G6	148.02	380.01	802.59	976.69	1,779.28
G7	201.24	259.62	1,251.06	667.28	1,918.34

Units	Power (MW)	Emis. (kg/hr)	Fuel cost (\$/hr)	Emis. Cost (\$/hr)	Total cost
G8	135.91	286.30	864.11	735.85	1,599.96
G9	120.42	221.76	900.80	569.97	1,470.76
G10	100.43	28.68	128.39	73.72	202.10
G11	150.61	150.04	408.04	385.62	793.66
G12	43.93	(11.35)	120.16	(29.17)	90.99
G13	265.76	814.56	906.49	2,093.57	3,000.07
G14	150.31	158.99	427.17	408.64	835.81
G15	137.24	295.33	847.45	759.05	1,606.50
G16	150.15	148.69	401.65	382.16	783.81
G17	100.00	28.07	120.00	72.15	192.15
G18	270.24	849.72	786.03	2,183.96	2,969.99
G19	130.91	319.79	947.12	821.92	1,769.04
Total	2,952.77	5,789.29	13,821.62	14,879.63	28,720.49

In particular, Table 3 contains the final findings for the scheduling of the power system including 19 producing units. This table displays the actual operational status of each power plant for the pledged power output, considering the overall load of 2,912 MW. These findings also influence different payments for generating electricity outputs. This table also shows how the generating units use different power levels to support the power system and meet load demand. The IEEE-62 bus system's generating units produce a total of 2,952.77 MW of power to serve 2,912 MW of total load, including 40.77 MW of total loss. Some generating units are closed at maximum power limits based on the combination of power stations for the economic operation that is judged to have a minimum total cost. Each scheduled power output has varying effects on the individual cost and also consequence of the generating unit commitment to a minimum total cost as same as supports for pollution discharge where these results are in line with some previous works.

4. CONCLUSION

The IEEE-62 bus is an example system in this research to demonstrate how to solve the EOEB problem. Constraints on equality and inequality were considered during the simulations as operational restrictions. The findings indicate that different generations exhibit various traits and abilities. Smooth convergence rates are used to choose the solutions. The approach can reduce the time needed to find the EOEB problem's least cost as indicated by the iteration results. For the problem, this method has delivered better outcomes. HSABC seems firmly to be a new potential strategy for solving the EOEB problem under several operational limitations for the IEEE-62 bus system based on the solution quality and computational efficiency, hence HSABC Algorithm is dedicated to further research.

REFERENCES

- [1] I. Ahmed, M. Rehan, A. Basit, S. H. Malik, U.-E.-H. Alvi, and K.-S. Hong, (2022). "Multi-area economic emission dispatch for large-scale multi-fueled power plants contemplating inter-connected grid tie-lines power flow limitations," *Energy*, vol. 261, p. 125178, doi: 10.1016/j.energy.2022.125178.
- [2] M. Basu, (2023). "Multi-county combined heat and power dynamic economic emission dispatch incorporating electric vehicle parking lot," *Energy*, vol. 275, p. 127523, doi: 10.1016/j.energy.2023.127523.
- [3] S. Bu et al., (2024). "Energy, exergy, environmental, and economic analyses and multiobjective optimization of a DSORC system for waste heat utilization in low-concentration gas power generation," *Energy*, vol. 286, p. 129647, doi: 10.1016/j.energy.2023.129647.
- [4] J. N. R. Araujo and L. S. Batista, (2023). "A diversity-driven migration strategy for distributed evolutionary algorithms," *Swarm Evol. Comput.*, vol. 82, p. 101361, doi: 10.1016/j.swevo.2023.101361.
- [5] E. Y. Avila-Melgar, M. A. Cruz-Chávez, B. Martínez-Bahena, M. L. Eraña-Díaz, and M. H. Cruz-Rosales, (2023). "Parallel evolutionary algorithm for Water Distribution Network Design, using the Masters–Students model in distributed environment," *Appl. Soft Comput.*, vol. 135, p. 109986, doi: 10.1016/j.asoc.2023.109986.
- [6] Y. Abdi, M. Asadpour, and Y. Seyfari, (2023). "μMOSM: A hybrid multi-objective micro evolutionary algorithm," *Eng. Appl. Artif. Intell.*, vol. 126, p. 107000, doi: 10.1016/j.engappai.2023.107000.

- [7] A. N. Afandi, (2014). "Optimal scheduling power generations using HSABC algorithm considered a new penalty factor approach," in *The 2nd IEEE Conference on Power Engineering and Renewable Energy (ICPERE) 2014*, Bali, Indonesia: IEEE, pp. 13–18. doi: 10.1109/ICPERE.2014.7067227.
- [8] Y. Chen and E. A. Raad, (2022). "Application of novel economic emission dispatch by considering the benchmark of multi-stage steam turbines, spinning reserve, and emission loss function," *Energy Rep.*, vol. 8, pp. 8652–8660, doi: 10.1016/j.egy.2022.06.064.
- [9] S. Divya, M. K. Paramathma, A. Sheela, and S. D. Kumar, (2024). "Hybrid renewable energy source optimization using black widow optimization techniques with uncertainty constraints," *Meas. Sens.*, vol. 31, p. 100968, doi: 10.1016/j.measen.2023.100968.
- [10] C. Collados-Rodriguez, M. Cheah-Mane, E. Prieto-Araujo, and O. Gomis-Bellmunt, (2022). "Stability and operation limits of power systems with high penetration of power electronics," *Int. J. Electr. Power Energy Syst.*, vol. 138, p. 107728, doi: 10.1016/j.ijepes.2021.107728.
- [11] W.-K. Hao, J.-S. Wang, X.-D. Li, H.-M. Song, and Y.-Y. Bao, (2022). "Probability distribution arithmetic optimization algorithm based on variable order penalty functions to solve combined economic emission dispatch problem," *Appl. Energy*, vol. 316, p. 119061, doi: 10.1016/j.apenergy.2022.119061.
- [12] A. N. Afandi, I. Fadlika, and Y. Sulistyorini, (2016). "Solution of dynamic economic dispatch considered dynamic penalty factor," in *2016 3rd Conference on Power Engineering and Renewable Energy (ICPERE)*, Yogyakarta, Indonesia: IEEE, pp. 241–246. doi: 10.1109/ICPERE.2016.7904870.
- [13] K. Máslo, A. Kasembe, and M. Kolcun, (2016). "Simplification and unification of IEEE standard models for excitation systems," *Electr. Power Syst. Res.*, vol. 140, pp. 132–138, doi: 10.1016/j.epsr.2016.06.030.
- [14] M. Ahmadipour, M. Murtadha Othman, R. Bo, M. Sadegh Javadi, H. Mohammed Ridha, and M. Alrifay, (2024). "Optimal power flow using a hybridization algorithm of arithmetic optimization and aquila optimizer," *Expert Syst. Appl.*, vol. 235, p. 121212, doi: 10.1016/j.eswa.2023.121212.
- [15] G. H. S. Diniz, V. dos S. Miranda, and B. S. Carmo, (2023). "Dynamic modelling, simulation, and control of hybrid power systems for escort tugs and shuttle tankers," *J. Energy Storage*, vol. 72, p. 108091, doi: 10.1016/j.est.2023.108091.
- [16] M. Ahmed, S. H. Kamel, N. H. Abbasy, and Y. Abouelseoud, (2023). "A Gaussian random walk salp swarm algorithm for optimal dynamic charging of electric vehicles," *Appl. Soft Comput.*, vol. 147, p. 110838, doi: 10.1016/j.asoc.2023.110838.
- [17] L. Fan, T. Peng, H. Yu, L. Ding, Y. Zhang, and J. Ma, (2023). "Optimization method of flexible response capability of power system with limited cost constraint," *Energy Rep.*, vol. 9, pp. 1069–1076, doi: 10.1016/j.egy.2023.06.044.