

# DESIGNING INVENTORY INFORMATION SYTEM OF FINISHED GOODS FOR VARIA USAHA BETON, Co. Ltd

<sup>1</sup>EMMY WAHYUNINGTYAS

<sup>1</sup>Informatics Engineering Program, Faculty of Engineering, Wijaya University Kusuma Surabaya

Jl. Dukuh Kupang XXV/54 Surabaya

e-mail: <sup>1</sup>emmy@uwks.ac.id

## ABSTRACT

*Nowadays, the web-based information system is widely used in various fields, including at PT. Varia Usaha Beton Gresik. Data Collection Inventory of finished goods needs to be done in order to know the residual of pre-printed concrete sold and guarantee the smooth flow of goods. Therefore, it is necessary to record all revenue received from the realization of production (input) and delivery realization (output). The data recording aims to be easily identified by the overloaded goods and the goods that must be reproduced because of stockout, and to integrate data among the general affairs division, production division, PPIC (Production Planning Inventory Control) division to support the delivery process.*

**Keywords:** *Information Systems, inventory, system design, finished goods*

## 1. INTRODUCTION

PT. Varia Usaha Beton Gresik is a manufacturing company producing concrete products. The products produced are pre-molded concrete such as pile, girder, collar, saddle and also producer of masonry concrete such as tile, hollow and paving block and machine broken stone/base coarse and also other building materials made from cement.

Data collection of finished goods or pre-printed concrete stored in the warehouse needs to be easily managed to know how many stocks of goods in the warehouse and to ensure smooth flow of goods and to facilitate inventory information of finished goods in PT. Varia Usaha Beton Gresik. Division of Production Planning Inventory Control (PPIC) also takes a long time to get inventory report of finished goods because it must be recording the data of goods incoming and outgoing goods in the warehouse and the report submission of each division also takes a long time too, because the distance location. This certainly makes PPIC performance less efficient.

The research goal is to develop system that can manage stock data and their statistics and to deliver reports for company management through the web based system.

## 2. LITERATURE REVIEW

### 2.1 Inventory

The word inventory such as raw materials, components, semi-finished goods, or finished goods, etc.) that are deliberately stored as a safety or buffer stock to face scarcity during the production process. Bigel (1990), that Inventories may be in the form of raw materials for processing, semi-finished goods and ready-to-sell goods so that inventory actually has a very important function for industrial enterprises. Sudana (2007), inventory is raw materials, semi-finished goods, finished goods that are in the production system at a time, which is an idle buffer that has economic value in the future when active. Munandar (1991), that the definition of inventory is the inventory of goods that become the object of the company's main business, for the trading company of goods in the form of merchandise inventory, while for the company producing (industry) auxiliary materials, inventories of processed goods and finished goods inventory.

Inventory of goods according to its function is divided into three types, they are (1) Batch Stock/Lot Size Inventory; that is inventory for the purchase or making of materials or goods in an amount greater than the amount required at that time, (2) Fluctuation Stock; inventories that is deal with unpredictable consumer demand fluctuations, (3) Anticipation Stock; inventories with predictable fluctuations in demand, based on seasonal patterns within a year and to face increased use or sales or demand.

## 2.2 Information System

Sutabri (2005) stated that information system is a system within an organization that reconcile the needs of daily transaction processing that supports the function of organizational operations that are managerial with the strategic activities of an organization to be able to provide to certain outsiders with the necessary reports. To be able to combine data that comes from various sources of a transformation system so that data is combined to have the compatibility of the data it stores (Fatta, 2009). Information systems according to Robert A. Leitch and K. Roscoe Davis in Jogiyanto (2005) is a system within an organization that brings together daily transaction processing needs, supports operations, managerial and strategic activities of an organization and provides certain outside parties with reports required. The information system is an organized data collection along with its use that covers more than just presentation. The term implies an intention to be achieved by selecting and managing the data and arranging the procedures for the use of information systems.

The success of an information system depends on three main factors, namely the harmony and quality of data, organizing data, and procedures use to meet user requirements so the structure and how it works depending on each functionality. The similarity among various information system is that they are combining various data collected from various sources and deliver reports.

## 3. RESEARCH METHODOLOGY

This study was conducted in several stages ie. data collection, system design, prototyping cycle-1, coding, prototyping cycle-2 and documentation. (1) Data collection stage; such as literature study, field study and company's document study. (2) Literature study, In this case the researchers compare, whether the previous literature can assist in the development of the proposed system. In addition the researchers also compared whether the developed system has advantages of the system made based on similar literature or earlier elsewhere who have used the information system, (3) Field study consists of two phase they are observation of the company's business process and interview with the persons in charge. (4) System Design, building DFD and ERD. There are 3 entities in the inventory information system of finished goods that is entity Leadership, Warehouse entity and entity PPIC. Where in each entity there is a flow that explains the process of inventory information system of finished goods. Entity Relationship Diagram (ERD) as the design for the system database. There are some entities that are incoming goods, goods out, goods data, history, land area customers and users, where each entity has its own attributes. (5) Prototyping Phase-1, in this stage a web interface is created. Whether with the look that has been done in accordance with the wishes of stakeholders or stakeholders can easily understand the view. At this stage developers create the system. Whether the system is running or not to be a prototype that is ready to be tested to stakeholders. (6) Coding, At this stage, php programming was done with XAMPP application, Google Chrome and Sublime Text. (7) Prototyping Phase-2, in this stage the developer improves the appearance of the web interface that has been evaluated by stakeholders. Developers change the look that was made before the user. Improving the system that has been made before. From the previous stakeholder evaluation results we developed previous.

## 4. ANALYSIS

The process flowchart contains the existing system workflow on the Inventory Information System. Consists of 2 process flowcharts, ie process flowcharts for incoming goods and flowchart of goods out. Incoming goods flowchart is shown by figure 1.

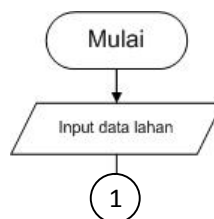

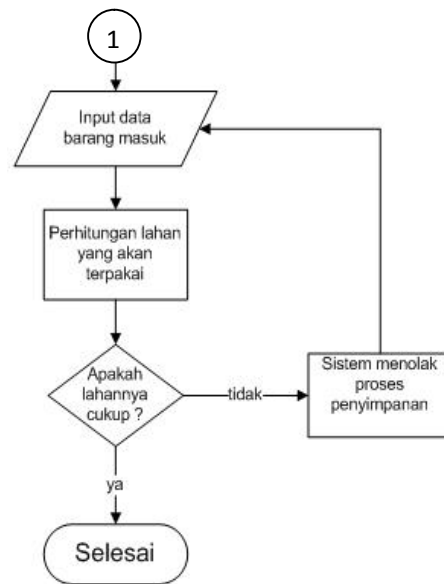

Figure 2. Flowchart of Incoming Goods

The next algorithm is the process of outgoing goods, only the user of warehouse and PPIC (admin) that can make the transaction process goods out on this system. The flowchart of outgoing goods is shown by figure 2.

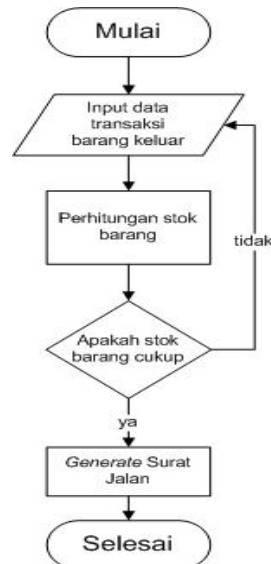

Figure 2. Flowchart Of Outgoing Goods

## 5. SYSTEM DESIGN

### 5.1 Context Flow Diagram

In the context of the diagram of this finished goods inventory information system describes the flow of processes in general with PPIC (admin), warehouse and leaders as users. The context diagram of this system is shown in Figure 3 below.

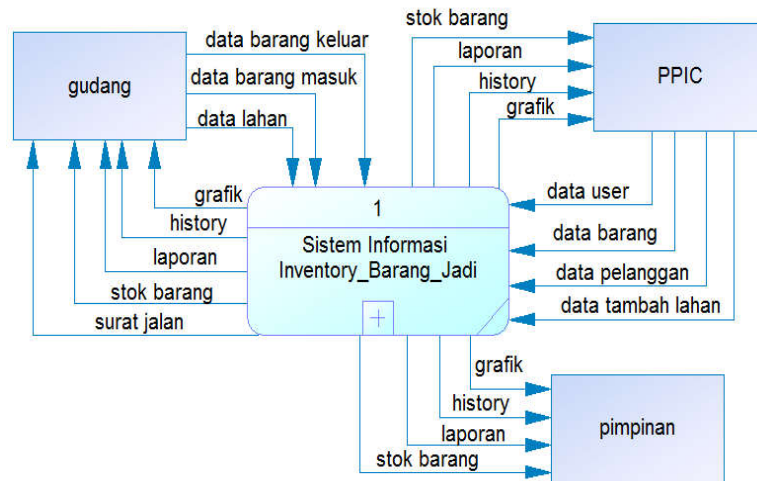

Figure 3 Context Flow Diagram

### 5.1 Data Flow Diagram Level 1

In DFD Level 1, the inventory information system of finished goods is the result of the translation from the previous context diagram. DFD Level 1 inventory information system of finished goods will be shown in Figure 4 below. In this level 1 DFD the outline of the context diagram, which has eight main processes namely (1) Input land area, warehouse units must input the name and total land area that will be used first before running the system. (2) Input transactions, in this process the user of the warehouse that inputs the transaction data of goods, among others, sales order number, date, customer name, item name, quantity of goods, piles, truck number, project / delivery, driver and sender name (internal / external) this will be stored in the data store transaction data goods. (3) Reporting, in the process of making report all users can view reports of incoming goods and goods out and can filter per date, per month or per year. (4) Creating visual report, in the process of making this visual reports, all users can see the graph of incoming goods and goods out and can filter per date, per month or per year. (5) Making history, in the process of making history all users can see the history of incoming goods and goods out and can filter per date, per month or per year. (6) Generate Delivery Order, this process automatically runs after successfully doing the process of goods out and can be downloaded or printed. (7) Calculate stock of finished goods, in this process the system will calculate the stock of finished goods with the formula of goods data entry minus the data of goods out and will be stored in the data store stock of goods. (8) Calculation of land capacity, this process si to calculate the capacity of the land with the calculations that is broken down to Level 2 of DFD.

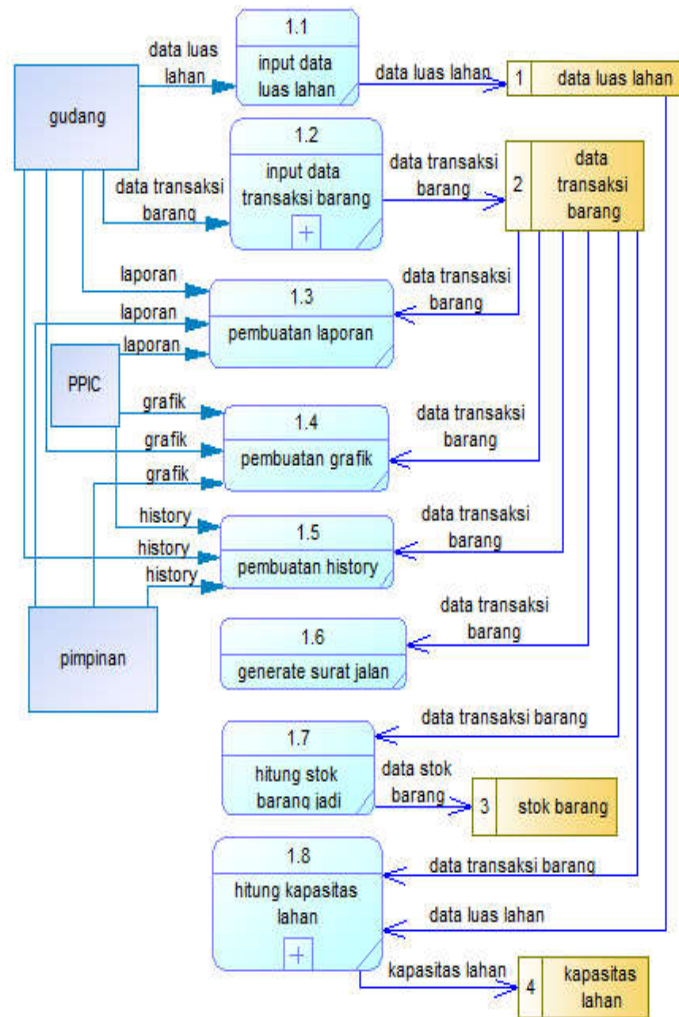

Figure 4 DFD Level 1

### 5.2 Conceptual Data Model

Contains an explanation of relationships between tables that exist in this inventory information system of finished goods. CDM (Conceptual Data Model) and PDM (Physical Data Model) of this system will be shown in the figure 5. Tables in Figure 5 is the main table used to store data on the inventory information system of finished goods, where each table has a relation that links between each table one with another table. There are 6 entities, where each entity has its own attribute / field. The customer orders the goods, then the goods are recorded the amount of goods, date of entry and date of exit to history and store the goods to the incoming goods. Then the goods will be stored on the land.

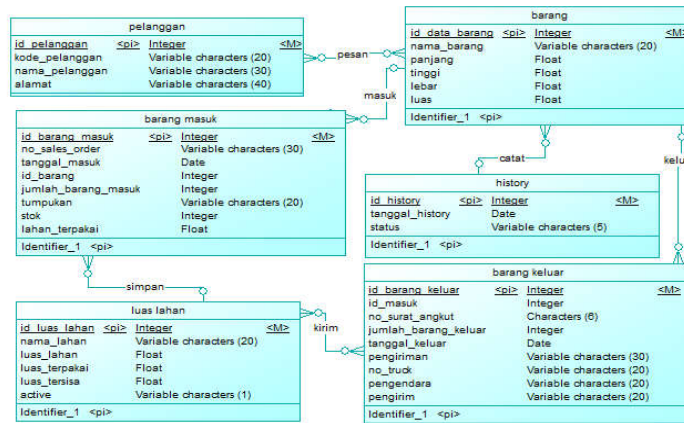

Figure 5 Conceptual Data Model

Each entity has attributes required in the design of the table structure on the database.

### 5.3 Physical Data Model

Physical data model (PDM) is generated from CDM. This model describes us the structured of data in the system, how they will be saved physically as shown in Figure 6. Two new entities generated because of the relationship among them refers to the same key.

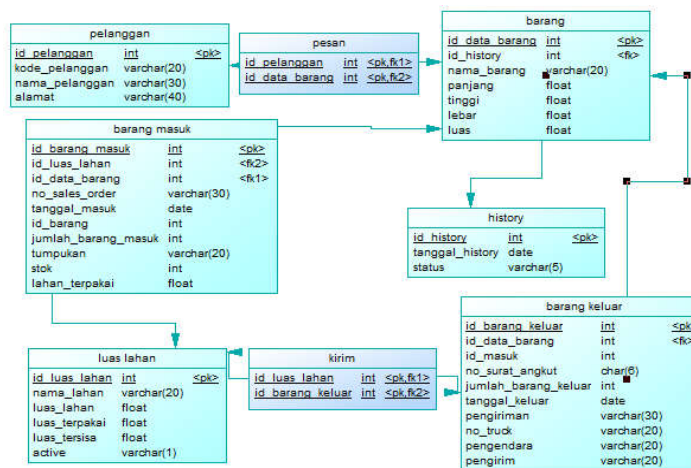

Figure 6. Physical Data Model

### 5.4 Interface Design

This section contains all of the system interface design, including input form and output as layout of reports it produces. The login page is the main page of the finished goods inventory information system. On this page the user must enter the username and password first in order to run this system. The login page can be seen in Figure 7 below. This is the main access page consists of inputting username and password. This page becomes the main page when the user accesses the system.

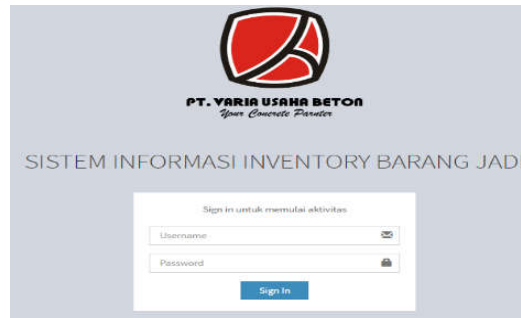

Figure 7. Interface Design Of Dashboard For Administrator

Admin dashboard page is the starting page for PPIC user or here as admin. Admin dashboard page can be seen in Figure 8 below. This is a Dashboard Admin page consisting of land select, land, transaction (incoming and outgoing goods), history, goods data (stock and data of goods out), graphs, user data, customer data, master data items, reports and logout.



Figure 8. The Interface Design Of Master Customer Input Form

The warehouse dashboard page is the starting page for the warehouse user or on this system as a transaction processor. The warehouse dashboard page can be seen in Figure 9 below. This is Warehouse Dashboard page consisting of transactions (incoming goods and goods out), history, goods data (stock and data items out), charts, reports and logout.



Figure 9. Warehouse Dashboard Page

The graph page is the page that will display the goods graph in and out items and can choose the graphs per month. The goods graph page can be seen in the following figure 10. This is a graphic page of goods that only show the graph of goods in the warehouse that contains the number of goods and dates and can be printed and downloaded.

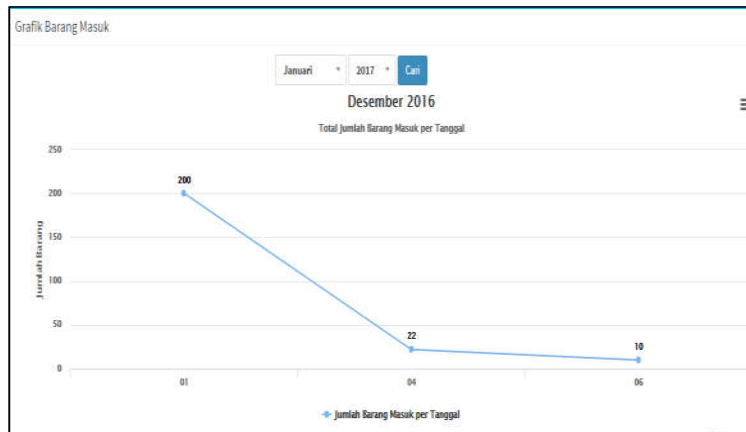

Figure 10. The Interface Design of Master Production Schedule (MPS)

## 6. CONCLUSIONS

From the discussion that has been described then the authors make the conclusion that the system of inventory information of finished goods is built using the programming language PHP and connected with MySQL database, inventory system design based on web base so that more dynamic and look user friendly, panel and column product transaction process only, A director and PPIC can quickly see stock, report and graphic of finished goods without having to wait for their warehouse part.

## REFERENCES

- [1] Jogiyanto, HM. 2015. *Analisis Dan Desain ; Sistem Informasi Pendekatan Terstruktur Teori & Praktek Aplikasi Bisnis*. Penerbit Andi, Yogyakarta.
- [2] Kendall, Kenneth E dan Kendall, Julie E. 2014. *Analisis dan Perancangan Sistem jilid 1*. Pearson Education Asia Pte. Ltd. dan PT Prenhallindo, Jakarta.
- [3] Ladjamuddin, Al-Bahra bin. 2016. *Analisis dan Desain Sistem Informasi*. Graha Ilmu, Yogyakarta.
- [4] Mcleod, Raymond dan Schell, George. 2015. *Sistem Informasi Manajemen*. PT INDEKS, Jakarta.
- [5] Peranginangin, Kasiman. 2016. *Aplikasi Web dengan PHP dan MySQL*, Edisi pertama. Penerbit Andi, Yogyakarta.
- [6] Pressman, Roger. 2017. *Rekayasa Perangkat Lunak Pendekatan Praktisi, Buku Satu*. Penerbit Andi, Yogyakarta.