

BASIC VLC INFRASTRUCTURE DESIGN USING TWO COLOR DIFFUSE LED AS RECEIVER AND COLOR INTENSITY MODULATION

HERTI MIAWARNI

Electrical Engineering, Technic Faculty, Bhayangkara Surabaya University

Surabaya

e-mail : herti_mia@ubhara.ac.id

ABSTRACT

VLC technology continuously developed until now. Development ranging from modulation system, basic infrastructure, up to complex networks. In this research conducted an experiment in terms of basic infrastructure which Diffuse LED is used as the main component on VLC receiver. The purpose of this research is to design and then analyze in an effort to build the basic infrastructure of VLC. Experiment performed on a simple modulation system for easy analysis process. For more simplicity, Color Intensity Modulation using only two colors: red and blue to present the logic high and low. From trials that have been done, Diffuse LED that used as the main component in the Receiver Unit has performed well in the period of the signal greater than or equal to 20 uS. In these conditions, BER reaches 0%. So in other words the shortest period of signal reaches a maximum of 20 uS and maximum bit rate of 100 Kbps. And then observations using the oscilloscope showed that in the same signal period, information signal shape that has been received are similar with the shape of signal that has been sent. Overall results, VLC system that has been designed and analyzed suitable for low bit rate communication.

Keywords : *VLC, Basic Infrastructure, Experiment Design, LED As Receiver, Color Intensity Modulation.*

1. INTRODUCTION

VLC (Visible Light Communication) is a short-range communications technology for utilizing visible light as a communication medium. Besides free of RF interference, this technology also offers solutions in energy efficiency in the communication infrastructure. [2]. As one of the most recent technologies involving VLC is a Li-Fi. where wireless[2] internet network that generally uses RF media is replaced with light media. Until now, the technology is still being developed VLC. Therefore, in this research conducted experiments relating to the basic infrastructure of VLC. Especially design on transmitter and receiver system.

This research is related to VLC experiment where red and blue LEDs are used as the main element in the receiver. The purpose to design, testing and analyze in an effort to build the basic infrastructure that is reliable and simple as possible on VLC. Communication design oriented and tested on indoor lighting that generally using daylight fluorescence lamp. So in this case, daylight is an ambient light which is a major disturber factor in communication. The previous related research is related to Color Intensity Modulation (CIM) where in this research used the three primary colors to form a constellation [1]. LED is a component that can work as a photodiode and has a high selectivity to the wavelength of light [6]. This component is also very supportive for communication with bit rate up to 100 Mbps [8]. Previous research related to the design of VLC is implementation of PPM modulation on VLC for constant lighting [5]. Design VLC close range by optimizing the optical antenna [7]. Then the more complex designs where VLC is used for Ethernet networks using DPPM modulation that has been modified [3]. While VLC design on this research, an optical antenna that used is relying on the LED lens. Then PPM and DPPM modulation can be implemented if basic infrastructure has high reliability especially at receiver. If the design of the system in this research is quite good performance by using the CIM, it is possible designs that have been made can be combined with PPM modulation with many variant.

2. DESIGN OF MODULATION AND DEMODULATION PROCESS

In this research, the design of VLC includes a transmitter and receiver. On the transmitter side, used Led Array made of Blue Super Bright LED with a wavelength of 625 nm and Red Super Bright LED with a wavelength of 430 nm. While on the receiving side, use Blue Diffuse LED with a wavelength of 430 nm and Red Diffuse LED with light emission on wavelength of 625 nm.

2.1 Modulation Process

Color Intensity Modulation in this research only uses two colors, Red and Blue that emitted by Super Bright LED. Thus there are only two symbols of information that is logic 1 (High) and 0 (Low). So data information is sent serially every bit. If information signal is expressed in the constellation diagram, then as shown in Figure 1.

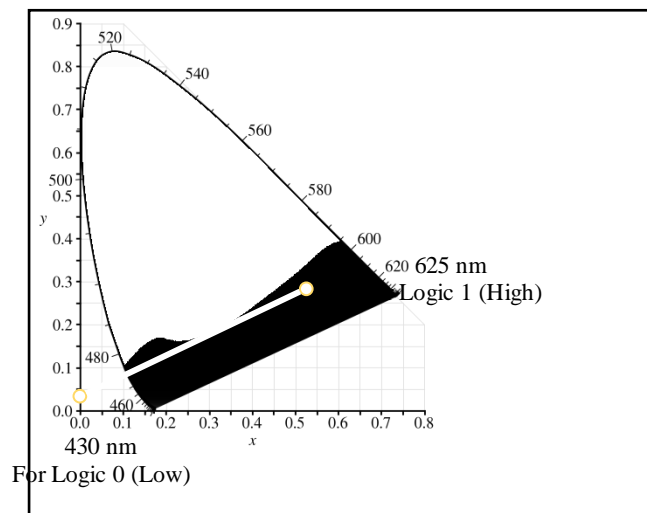

Figure 1. CIM Constellation Diagram

Generally On Off Keying (OOK) modulation especially optical Amplitude Shift Keying (ASK) modulation, if the information in the form of bit 0 (Low) and 1 (High), then the light source will be lit when the logic 1 and is extinguished when the logic 0 [9]. Thus, there was no significant difference between receiving data logic 0 (Low) with not receiving the information. Therefore, in this research used two basic colors with different wavelengths to represent both the logic. The system design as shown in Figure 2.

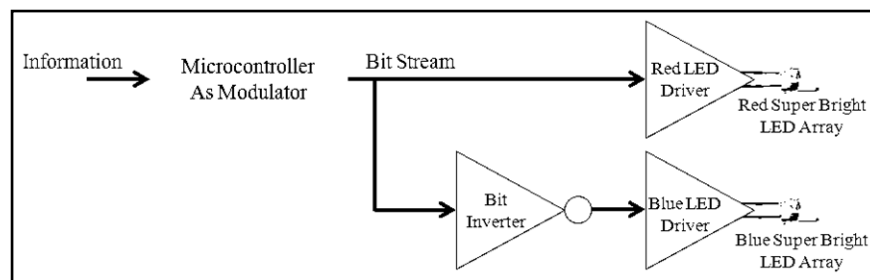

Figure 2. Complete VLC Modulation System Design

2.2 Line Coding, Maximum Bit Rate and Bit Error Rate Analyze

Then in terms of line coding, signal format that used in this research is NRZ-L (Not Return to Zero - Level). The reason for using this line coding is the ease and compatibility of the hardware that uses a single supply. In addition, this scenario is used to test the system as a whole, especially the maximum bit rate and the system's ability to maintain the shape of the signal that has been sent to the receiver. In this case, each one signal period (T) representing 2 baud and 2 bits of the information signal. So the Maximum Bit Rate is $(2 \times 1/T)$.

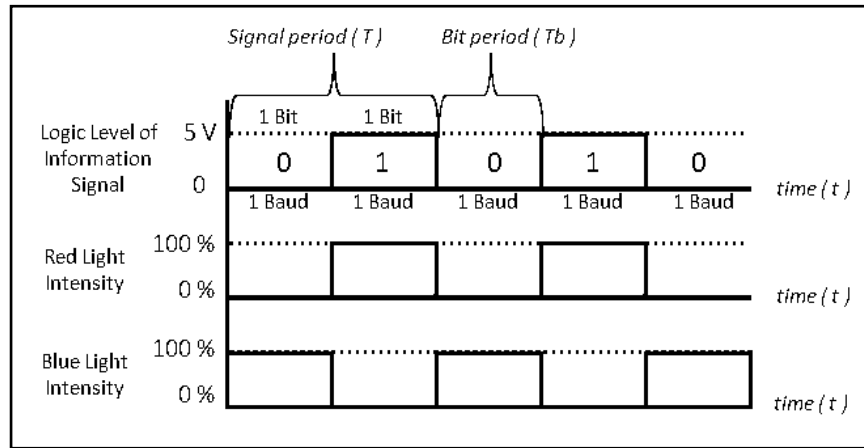

Figure 3. Line Coding Scenario

Bit Error Rate (BER) analysis is used to test the maximum bit rate signals emitted at different signal period condition. According to [4] Bit error rate is a risk of error where the logic that has been emitted by the transmitter is recognized as a different logic at the receiver. So that BER can be simply stated as follows.

$$Pec = \frac{1}{2} P(e|1) + \frac{1}{2} P(e|0) \quad (1)$$

Where Pec is conditional error probability and $P(e/0)$ is the probability that the received signal is a logic 1 (High) while the transmitted signal is a logic 0 (Low). While $P(e/1)$ is the probability that the received signal logic 0 (Low) while the transmitted signal is logic 1 (High).

2.3 Demodulation Process

On the demodulation side, the Red and Blue Diffuse LED is the primary sensor for 2 pieces detector circuit (Red Light and Blue Light Detector). Analog comparator is used to selection and pass the data from the two detectors are strongest. Data information (D) that has been accepted will be recognized as Logic 1 (High) if the amplitude of the signal at the output of the red light detector (A_{red}) is greater than the output of blue light detector (A_{blue}). Vice versa. So mathematically be expressed into the following rules:

$$D = 1 \text{ if } \{ A_{red} - A_{blue} > 0 \} \text{ and } D = 0 \text{ if } \{ A_{red} - A_{blue} \leq 0 \} \quad (2)$$

Then, the comparator output is generally not free from noise and Transition Time caused by the characteristics of the component analog comparator. So it takes a process for the recovery of information bits to fit the shape of the signal emitted by the transmitter. The working principle of the process is a threshold voltage ($1/2 \times V_{cc}$) at the output of the analog comparator. If the data information before the recovery process remains expressed as (D) and data recovery information that have already been declared as (D_{rec}), then Pulse shape recovery process can be expressed by the following equation:

$$D_{rec} = 1 \text{ if } \{ D > (1/2 \times V_{cc}) \} \text{ and } D_{rec} = 0 \text{ if } \{ D \leq (1/2 \times V_{cc}) \} \quad (3)$$

Therefore output of Pulse Shape Recovery process becomes smooth Square wave. In other words, the output of Pulse Shape Recovery is Bit Stream information that ready to use. While a complete VLC demodulation system design is as shown in Figure 4.

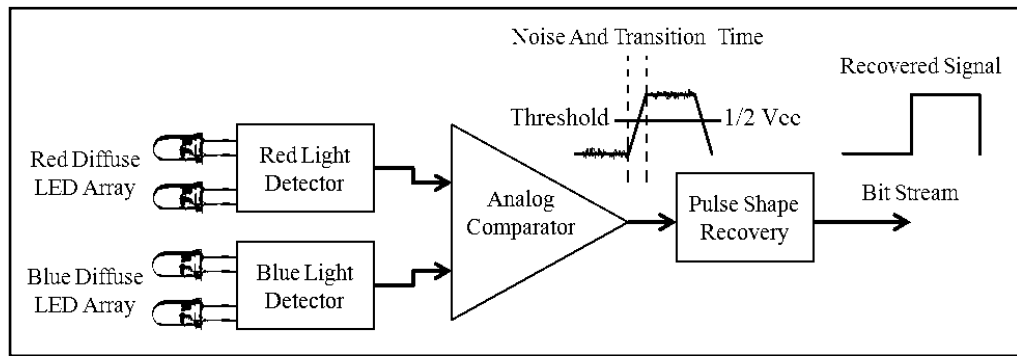

Figure 4. Complete VLC Demodulation System Design

3. TRIAL AND ANALYZE

After overall design of both the transmitter and receiver, the next process is testing and analysis. There are two important points of the trial and analysis in this research. The first point is a trial of maximum bit rate that can be sent or received. As for the second point is observation using an oscilloscope to analyze the shape of the signal at the receiver unit. The better the performance of the system will generate a received signal approximates the shape of the information signal has been sent. The second test was carried out by placing receiver and transmitter unit at a predetermined distance. The testing and analysis activities as shown in Figure 5.

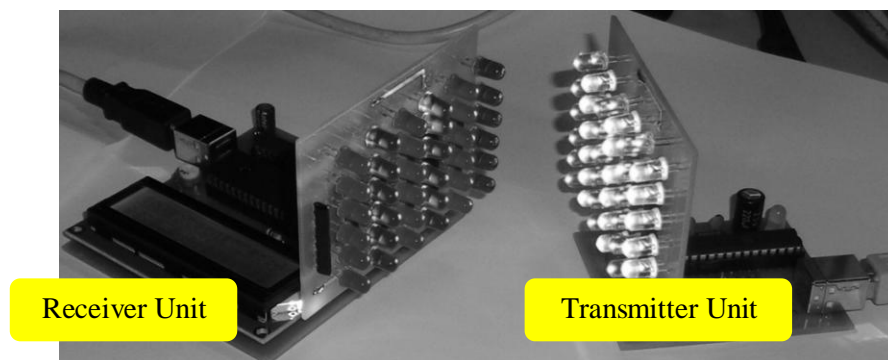

Figure 5. Trial And Analyze Process

3.1 Maximum Bit Rate and Bit Error Rate (BER)

At this session, test carried out by changing the signal period (T) emitted from a range of 1 microsecond to 1.5 millisecond. Then the bits of information that has been received by the Receiver Unit will be compared with the bits of information that has been sent by the Transmitter Unit. The number of bits that error will be counted manually and then analyzed using probability equations as in Equation 1. The process of testing performed on two conditions of the room. Namely when lighting the room in a state of maximum and when the room dark conditions. The test results are as shown in Figure 6. Where the ideal conditions obtained in the period of maximum signal 20 μ S. Or Maximum Bit Rate ($2 \times 1/20 \mu$ S) = 100 Kbps. Then, differences in room lighting conditions affect the performance of LEDs as a main component in the Receiver Unit. From the test results, the performance of LED signal is impaired in the period between 0.5 to 15 μ S.

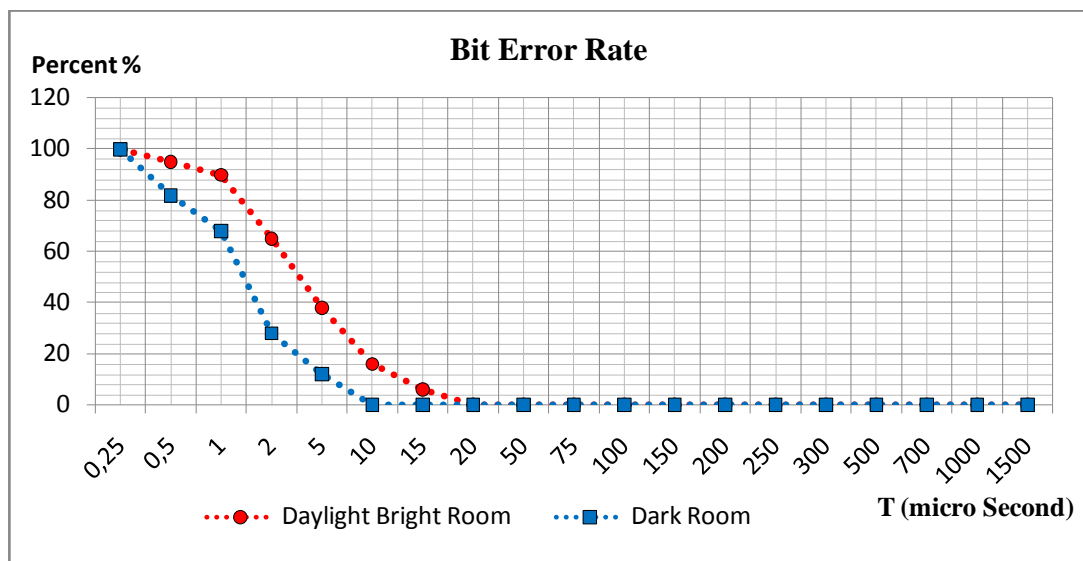

Figure 6. BER Trial Result

3.2 Pulse Shape on Receiver Unit

Trial at the next session is an observation using an oscilloscope to observe the signal shape of the signal information received by the Receiver Unit. The trial is carried out on different signal periods as in the first trial. The results of test are shown in Figure 7a, 7b, 7c and 7d.

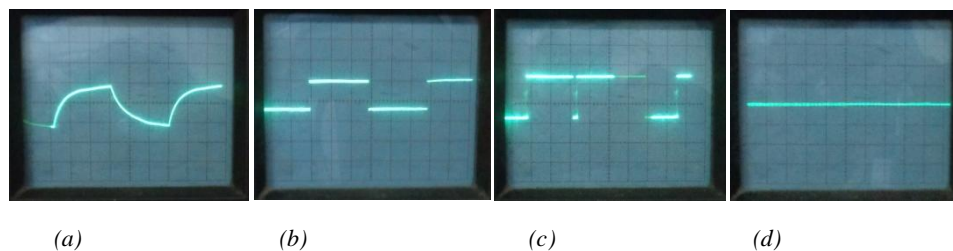

Figure 7.a. Pulse Shape Before Pulse Shape Recovery ($T \geq 20 \mu\text{s}$)
 Figure 7.b. Pulse Shape After Pulse Shape Recovery ($T \geq 20 \mu\text{s}$)
 Figure 7.c. Pulse Shape After Pulse Shape Recovery ($T = 10 \mu\text{s}$)
 Figure 7.d. Pulse Shape After Pulse Shape Recovery ($T \leq 1 \mu\text{s}$)

Figure 7a shows the shape of the signal from the signal information before the Pulse Shape Recovery. Logic 1 is represented as a line sloping upward and logic 0 is represented as a line sloping downward. Signal information can be restored to forms of origin after passing through the recovery process as shown in Figure 7b. In this condition, the shape of the signal information received is similar with the shape of the signal information has been sent. Then Figure 7c show the occurrence of bit errors, especially during the period of the signal less than 20 μs . This condition occurs during the period of the signal sent on the range of 0.5 to 10 μs . And Figure 7d show where the information signal is not detected at all. This condition is declared Loss or BER = 100%.

4. CONCLUSION

This research has been carried out experiments related to basic VLC infrastructure design. Where used Color Intensity Modulation (CIM) which use red and blue to represent logic 1 and logic 0 of signal information. The trial results showed that in terms of performance LED, LED Diffuse that used in the design of system got disturbance during period signal less than 20 μs . This disorder is caused by ambient light of the room though not significantly. Conversely, communication system proved reliable during the period of the signal greater than or equals to 20 μs . In addition, test results also showed that the maximum bit rate that can be sent is 100 Kbps with signal period for 20 μs . These results were confirmed by the analysis of BER reaches 0% and form of signal information that received similar with the form of the information signal is sent. But according to previous studies, these results are under

expected. However, when used for low bit rate communication systems such as communications between sensors. This design is very worthy to be considered as an advanced research.

REFERENCES

- [1] Ahn, K.I. and Kwon, J.K. (2012). *Color Intensity Modulation for Multicolored Visible Light Communications*, IEEE Photonics Technology Letters, Vol. 24, No. 24, pp 2254-2257.
- [2] Arnon, S. (2016). *Visible Light Communication*, 1st edition, Cambridge University Press, United Kingdom.
- [3] Delgado, F., Quintana, I., Rufo, J.A, Rabadan, Quintana, C., and Jimenez, R.P, (2010). *Design and Implementation of an Ethernet-VLC Interface for Broadcast Transmissions*, IEEE Photonics Technology Letters, Vol.14, No. 12, pp 1089-1091.
- [4] Ghassemloy, A., Popoola, W., and Rajbhandari, S, (2013). *Optical Wireless Communication, System And Chanel Modelling With MATLAB*, CRC Press Taylor & Francis Group, Chapt.4, no.239.
- [5] Pradana, A., Ahmadi, N., Adiono, T., Cahyadi, W.A, and Chung, Y.H. (2015). *VLC Physical Layer Design based on Pulse Position Modulation (PPM) for Stable Illumination*, International Symposium on Intelligent Signal Processing and Communication Systems (ISPACS), pp. 368-373.
- [6] Rossiter, J. and Mukai, T. (2005). *A Novel Tactile Sensor Using a Matrix of LEDs Operating in Both Photoemitter and Photodetector Modes*, IEEE Sensor ICSENS.
- [7] Shin, H., Park,B., Jung, D.K, Lee, Y.M, Song, S., and Park, J. (2011). *VLC Transceiver Design for Short-Range Wireless Data Interfaces*, IEEE ICTC, pp. 689-690.
- [8] Stepniac, G., Kowalczyk, M., Maksymiuk, L., and Siuzdak, J. (2015). *Transmission Beyond 100 Mbit/s Using LED Both as a Transmitter and Receiver*, IEEE Photonics Technology Letters, Vol. 27, No. 19, pp 2067-2070.
- [9] Tri, T.H., (2011). *Theory And Design Of Digital Communication System*, Cambridge University Press, Chapt.6, page.236, United Kingdom.